

---

# Installation, Operation and Maintenance Manual

---

## Wood-Burning Ovens for Pizza / Series D /

- Design C
- Design S
- Design K

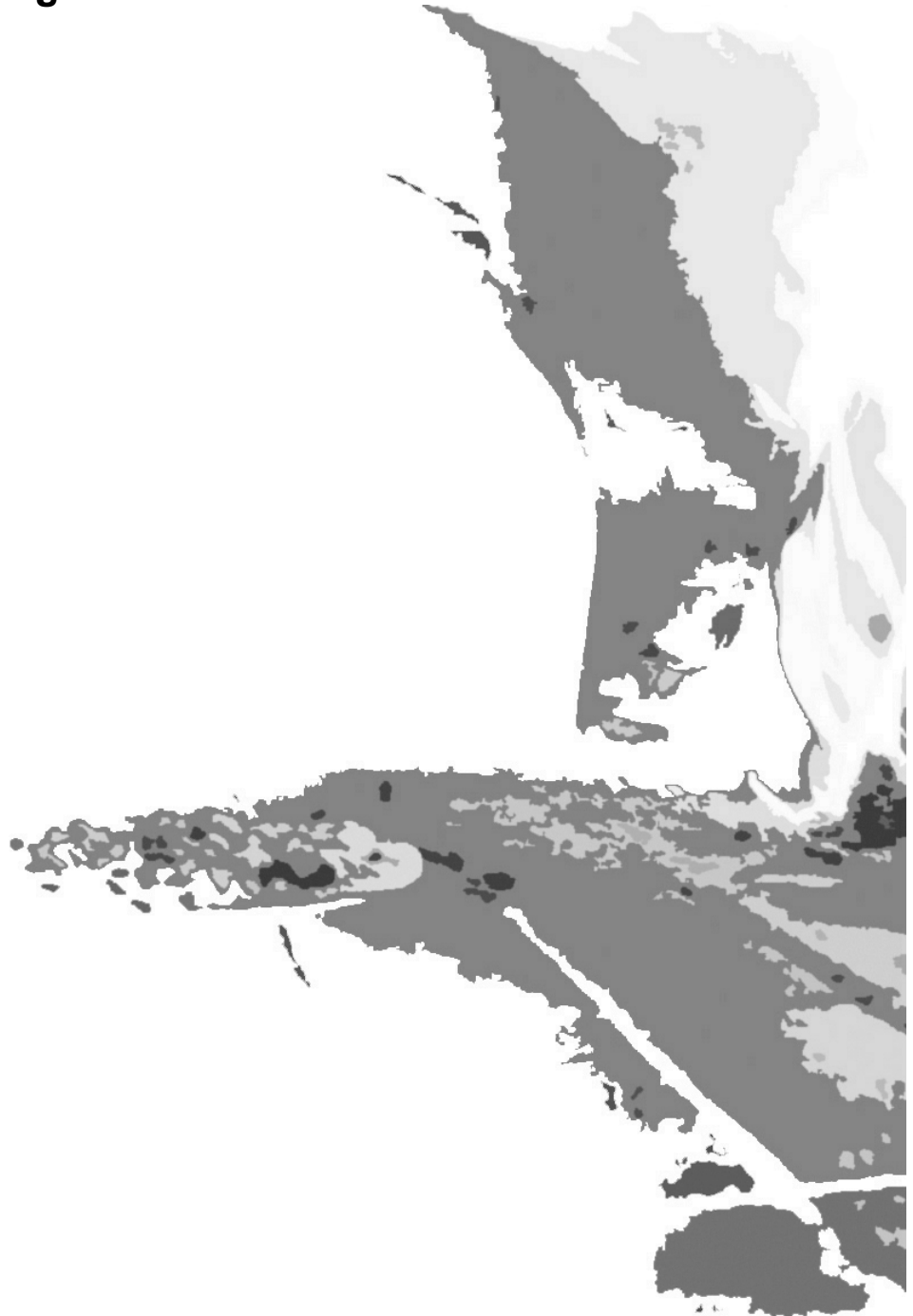

# Table of Contents

<b>Introduction and Safety</b> .....	2
<b>Transportation</b> .....	4
<b>Product Description</b> .....	6
<b>Installation</b> .....	7
<b>Operation</b> .....	9
<b>Maintenance</b> .....	11

# Introduction and Safety

## Introduction

### Purpose of this manual

The purpose of this manual is to provide necessary information for:

- Installation •Operation •Maintenance



### CAUTION:

Read this manual carefully before installing and using the product. Improper use of the product can cause personal injury and damage to property, and may void the warranty.

The manufacturer is not liable for damages caused by wrong usage, constructive alterations, or replacement of spare parts with unoriginal ones.

### NOTICE:

Save this manual for future reference, and keep it readily available at the location of the unit.



## Safety terminology and symbols

### About safety messages

It is extremely important that you read, understand, and follow the safety messages and regulations carefully before handling the product. They are published to help prevent these hazards:

- Personal accidents and health problems
- Damage to the product
- Product malfunction

### Hazard levels

Hazard level	Indication
 <b>DANGER:</b>	A hazardous situation which, if not avoided, will result in death or serious injury
 <b>WARNING:</b>	A hazardous situation which, if not avoided, could result in death or serious injury
 <b>CAUTION:</b>	A hazardous situation which, if not avoided, could result in minor or moderate injury

Hazard level	Indication
 <p style="text-align: center;"><b>NOTICE:</b></p>	<ul style="list-style-type: none"> <li>• A potential situation which, if not avoided, could result in undesirable conditions</li> <li>• A practice not related to personal injury</li> </ul>

### Hazard categories

Hazard categories can either fall under hazard levels or let specific symbols replace the ordinary hazard level symbols.

Electrical hazards are indicated by the following specific symbol:



---

#### Electrical Hazard:

---

## Work and safety procedures

Only persons who are acquainted with the present manual can work with the oven.

Only qualified electricians can work on electrical fitting of the oven.

Lifting - transport operations can be carried out only by equipped, trained and instructed in the safety procedures personnel.

The oven and the working area have to be cleaned regularly in order not to be infested with insects, rodents and other pests.

Before starting work, examine properly the baking chambers for possible entry of a pest or pet.

A brush with long handle, that reaches the bottom, is needed for a preventive cleaning before starting work.

When damage is found, the operator has to consult a specialized repair team.

When performing oven repair work, the power supply must be turned off first.

# Transportation

## Lifting and removal

The oven has to be lifted and moved with the help of forklift or pallet truck by equipped and instructed in the safety procedures personnel. The oven has to be placed on well levelled platform. It is not necessary to be fixed to the foundation.

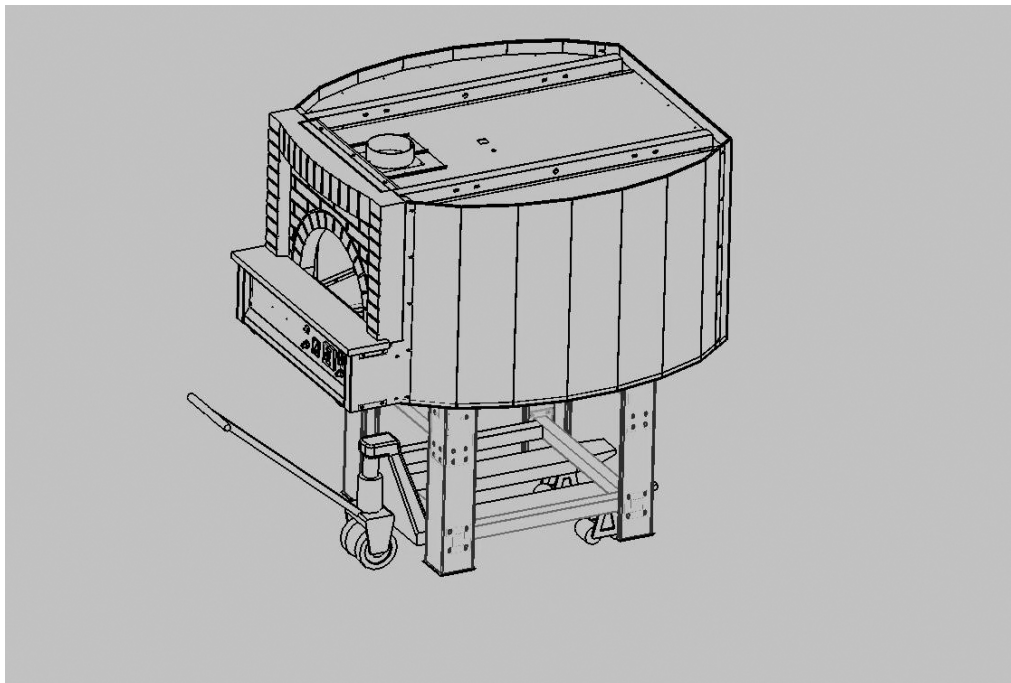
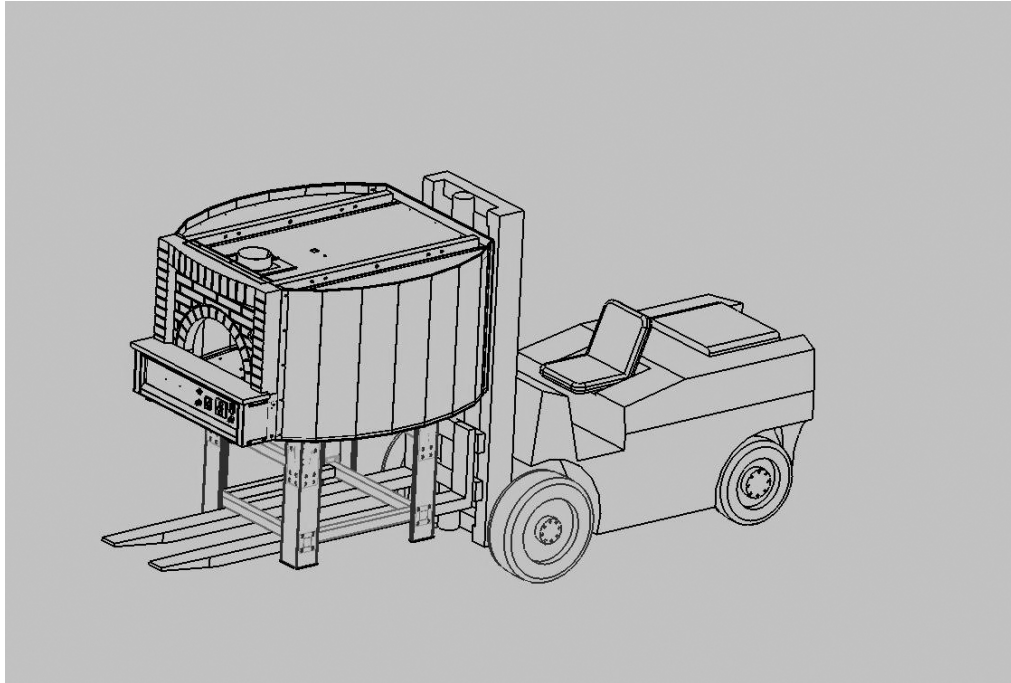

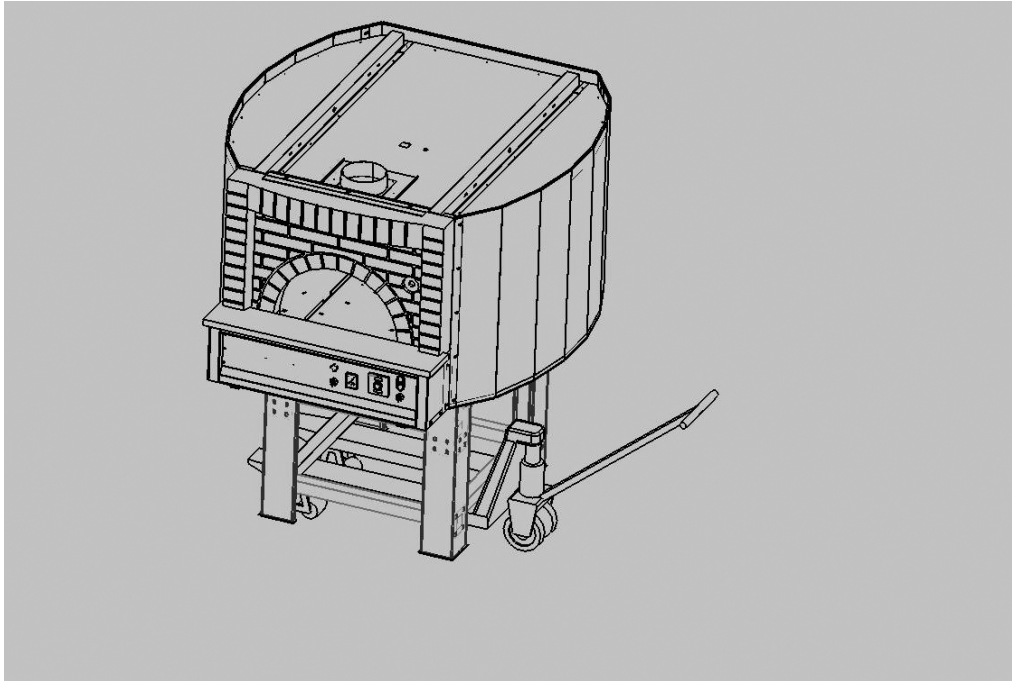

# Product Description

## General Description

The ovens of series D are of domical type and are assigned for baking of pizzas. They are made of vibrated refractory material with high percent of two--aluminum--three-oxide (Al<sub>2</sub>O<sub>3</sub>), which guarantees high wearing out resistance and sturdiness. The domical form of the baking chamber guarantees an even baking at low wood consumption. Insulation materials with low coefficient of heat conductivity have been used. The considerable thickness of insulation helps to achieve maximum economy. All elements of the oven are placed in a case which allows its mobility. It is manufactured in three major sizes.

## Consumption of Firewood per Hour /kg/

-D100	3-4
-D120	4-5
-D140	5-6
-D160	6-7

## Capacity Pizzas Ø30cm/deck

-D100	4
-D120	7
-D140	10
-D160	13

## Weight /kg/

-D100C/S	1100
-D120C/S	1350
-D140C/S	1700
-D160C/S	2100
-D100K	1300
-D120K	1500
-D140K	1900
-D160K	2300

## Productivity per Hour /number of pizzas/

-D100	60
-D120	105
-D140	150
-D160	195

# Installation

**WARNING:**

Installation and servicing of this product could expose you to glasswool/ceramic fibers as well as calcium silicate dust: always wear respiratory and eye protection when installing or servicing this appliance. Please read this entire manual before you install the oven: failure to follow instructions may result in property damage, bodily injury or even death. Contact your local building or fire officials about restrictions and installation inspection in your area.

## Leading Smoke Gases Away

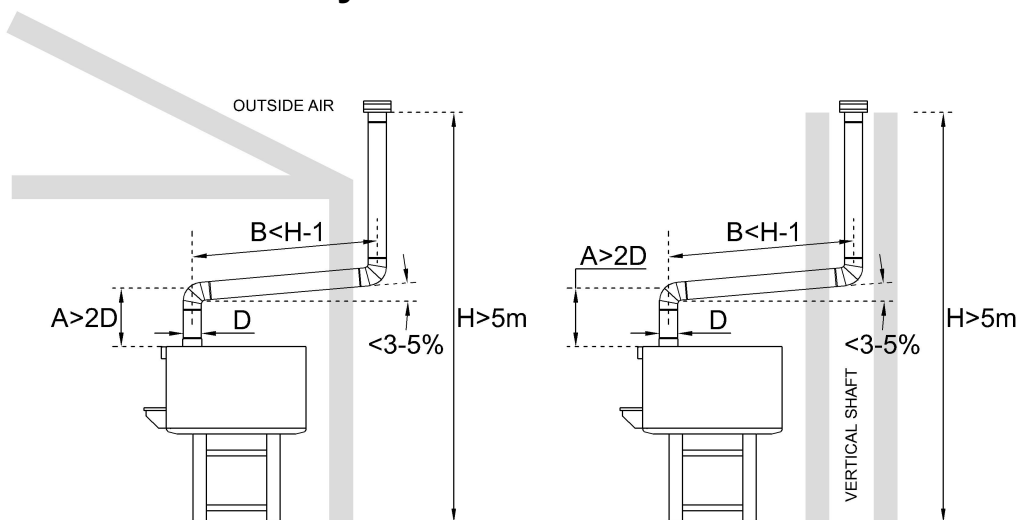

Connecting the oven into the chimney is done by chimney pipes which have to be in conformity with the following conditions:

- They have to be produced from materials made to endure the heat of the smoke gases and the possible delays.
- The connections have to be well sealed and the used materials have to endure heat and corrosion.
- They has to be easy visible, easy for dismantling and assembling, and provide a possibility for thermal expansion.
- A piece of vertical pipe with a length at least twice the diameter of the chimney's opening has to be installed at the outlet of the oven.
- After the piece of vertical pipe, a horizontal section with an inclination of at least 3 % can be installed. The length of this section does not have to exceed the useful height of the chimney.
- The change of direction is possible in no more than 3 places, including the chimney's inlet.
- The bends must not have an angle more than 90 degrees.
- The pipe - diameter along the whole length has to be permanent.

**WARNING:**

Do not pack required air spaces (clearance) with insulation or other material. When non-combustible building materials contact the body of the oven, the clearances to combustibles are transferred to those non-combustibles.



## Clearances

The Series "D" oven must have a minimum 25 mm clearance to combustibles from all sides, 150 mm clearance to combustibles from the top, and 150 mm clearance from the exhaust transition and flue collar. Any facade wall built 150 mm to either side of the doorway and above must be of non-combustible construction. If building a facade that will contact the oven, use completely non-combustible materials. Any walls perpendicular to the front of the oven in the area 750 mm to either side of the doorway and 900 mm in front of the oven should have a non-combustible surface.

This oven must be installed on a non-combustible floor surface. For use only on noncombustible floors. The non-combustible floor surface must extend 900 mm in front of and 750 mm to either side of the oven doorway.

## Installing the Door



The door is positioned deeper inside when the oven is not working. This way the chimney is insulated from the baking chamber.



This position of the door is used when the oven is working, but not baking pizzas.

The chimney is not insulated from the baking chamber.

This position of the door reduces heat loss and improves the comfort of the personnel.

# Operation

## Initial Heating

**NOTICE:**

The initial heating has to be carried out very carefully, gradually increasing the temperature and usually it is performed for 2 - 3 days because the moisture has to be separated from the baking chamber and from the isolation layer. Attention: sharply increasing the temperature in this period can lead to formation of cracks on the foundation and the cupola.

**NOTICE:**

Put the woods to the left part of the baking chamber and light them. Do NOT put them to the right side because you may damage the thermometer.

**•First day:**

- You must reach the temperature of about 100-150 degrees °C
- Leave the oven to work in these conditions for 8-10 hours

**•Second day:**

- Light the woods.
- You must reach the temperature of about 200-250 degrees °C
- Leave the oven to work in these conditions for 8-10 hours

**•Third day:**

- Light the woods.
- You must reach the temperature of about 300-320 degrees °C
- At reaching this temperature regime, the oven is ready to bake standard pizza

**NOTICE:**

This is the result when it is not followed the instructions for initial heating.



**CAUTION:**

Usually, in the period of initial heating, drops of water start leaking from the oven, because this is a period of intensive drying – Taking into consideration of this fact, electric devices and cable are not recommended to be placed in this zone.

---

# Maintenance

## Sanitary – Hygienic Maintenance

Pieces of dough fallen on the chamber's floor have to be cleaned daily with a brush with long handle, manually – by the operator.

Daily, the outside of the body of the oven has to be cleaned for dust with a soft towel.

At the end of every shift, the hard waste on the working area around the oven has to be cleaned with a brush and after that to wash and disinfect the floor.

**AS TERM Ltd**

144 Tsar Ivan Asen II  
4230 Asenovgrad, Bulgaria  
as\_term@abv.bg  
tel./fax +359 331 462 42



**PROFESSIONAL OVENS**

Static & Rotary Ovens  
Wood Ovens  
Gas Ovens  
Wood - Gas Ovens